

## Installation and service guide for AirMaid<sup>®</sup> V ozone cleaning system



**AIRMAID<sup>®</sup> OZONE CLEANING SYSTEM**

**INNOVATIVE AIR TREATMENT**

AirMaid<sup>®</sup> product registration





## WARNINGS AND SAFETY NOTICES

This guide describes a typical installation in a commercial kitchen exhaust duct. The product can also be used in other applications as long as the specific requirements according to the guide are fulfilled.

The device may not be used by children or by persons with diminished physical, sensory or mental capacity or lack of experience and knowledge unless supervised or having received instruction. Supervise children to ensure that they do not play with the device.

### General Information

The device may not be used by children or by persons with diminished physical, sensory or mental capacity or lack of experience and knowledge unless supervised or having received instruction. Supervise children to ensure that they do not play with the device.

1. This manual contains important information about instructions and safety concerning AirMaid® ozone generator (hereinafter referred to as the generator). Read this manual carefully before installation, commissioning or performing service and maintenance on the generator.
2. The generator is intended only for ozone treatment of air in accordance with the instructions in this manual.
3. The generator uses high voltage to create an electric discharge which generates ozone (O<sub>3</sub>). Ozone significantly reduces odours. Absolent CKV AB disclaims any liability if the product is not used according to the manufacturer's instructions in this manual.
4. Never clean the generator with chemical cleaning agents. Water or liquid shall not be sprayed onto or inside the generator. The cleaning of the ozone cell (CGC) shall be done while following the instructions in this manual.

### Troubleshooting and Service Information

1. The user can troubleshoot the generator by following the steps and procedures described in the System Test section in this manual. If the user needs to have the generator serviced, the user shall contact the closest authorised service partner or Absolent CKV's technical support.
2. All repairs on the generator must be performed by a service partner authorised by Absolent CKV AB.



The power supply to the generator must be cut off before any service or maintenance. Make sure that all parts have been installed before you turn on the generator again.



Use a ladder or a stable work platform when installing or servicing the generator if the installation or service must be done at a height.



The generator produces ozone. If the generator is used by persons who have not read this manual, there is a risk of injury such as eye or lung irritation. Always follow local regulations and the recommendations of government organisations that inspect the regulations or the work environment.



This user manual describes a typical AirMaid® 5000V/10000V/20000V/30000V ozone generator installation. The installation can vary depending on local rules and regulations relating to building materials, ventilation systems or the layout of the building/room. Deviations are possible but always consult the manufacturer before such installation.

### 3-YEAR PRODUCT WARRANTY

Submit the product registration form to Absolent CKV within ten (10) days after the completion of the installation in order to receive a **3-year warranty**. The warranty will then be valid from the installation date. The easiest way to do so is by scanning the QR-code the right and submitting the form. The whole process will only take a couple of minutes.

AirMaid® product registration



### LIMITED WARRANTY FOR Absolent CKV EQUIPMENT

This warranty is subject to the following conditions.

A new product is warranted to be free from defects and workmanship for a period of 3 years from the first delivery date. If a product registration is submitted to Absolent CKV within ten (10) days after the installation is completed, the warranty will instead take effect from the date of installation.

A spare part is warranted to be free from defects and/or workmanship for a period of ninety (90) days from the date of the original installation.

The warranty for new equipment covers the repair or replacement of the defective part and includes labor charges according the recommended hours by Absolent CKV and maximum kilometer charges of 300 km round trip.

The warranty for spare parts covers only the repair or replacement of the defective part and does not include any labor charges for the removal and installation of any parts, travel or other expenses incidental to the repair or replacement of a part.

Any claim must be presented to either Absolent CKV or the distributor from whom the product was purchased. No allowance will be granted for repairs made by anyone else without Absolent CKV written consent. If damage occurs during shipping, notify the sender at once so that a claim can be filed.

The above limited warranty does not apply to damage resulting from accident, alteration, misuse or if the serial number is removed or defaced.

## TABLE OF CONTENTS

- |                                       |                             |
|---------------------------------------|-----------------------------|
| 1. Check Product                      | 6. AirMaid® Startup         |
| 2. System Overview                    | 7. System Test              |
| 3. Installation Guidelines            | 8. Service and Maintenance  |
| 4. Electrical Connection and Settings | 9. Technical Specifications |
| 5. BACnet Connection and Settings     |                             |

## 1 CHECK PRODUCT

Check that the shipment consists of the components below and that there are no visible damages. Any discrepancy must always be reported to the distributor or manufacturer. Read through the complete guide before starting the installation.

1 x AirMaid® Ozone Generator



1 x AirMaid® Alarm Panel



## 2 SYSTEM OVERVIEW

You should carefully study the example installations below. Select the type of installation that works best for you and that complies with all national standards and regulations. If a central air supply cannot be used, a filter box EU3 class or higher is required; the air can be supplied from the area above a false ceiling or from the outdoors. In order to reduce the frequency of filter changes, the supply air should originate from a place containing the least possible impurities. The temperature of supply air should not exceed 40°C. AirMaid® is very effective in reducing odors provided that the reaction time between the ozone and the exhaust air in the kitchen duct is at least 3 seconds. This reaction time is important and must be taken into account during the planning stage.

SAMPLE ONE

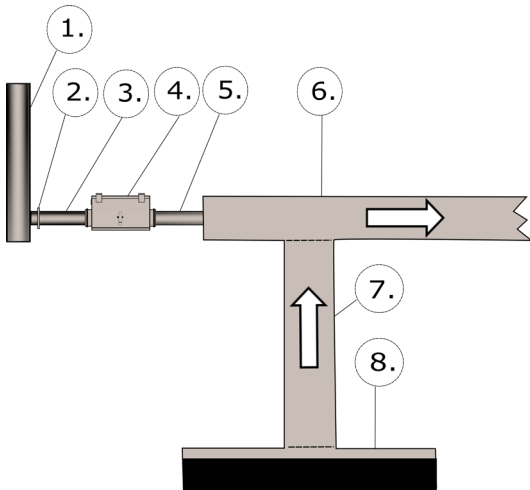

SAMPLE TWO

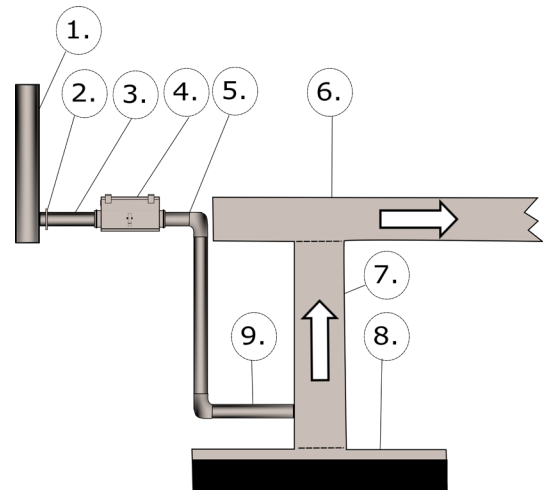

SAMPLE THREE

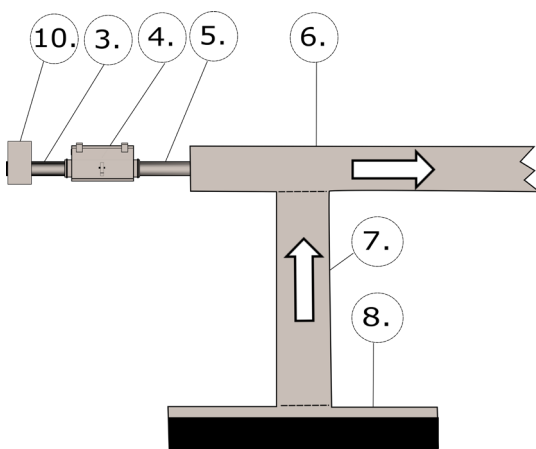

1	Central Ventilation (inlet)
2	Damper
3	Inlet tube Ø125 mm
4	AirMaid® Ozone Generator
5	Outlet Tube Ø 80-125 mm
6	Horizontal Exhaust Duct
7	Vertical Exhaust Duct
8	Kitchen Hood
9	90° Tube Ø 80-125 mm
10	Filter Box (EU3 class or higher)

### 3 INSTALLATION GUIDELINES

There has to be a gap of about 20 cm on all sides of the ozone generator for disassembly where applicable. Also, the service hatch opening at the bottom of the ozone generator must be accessible, so that it can be removed easily for annual service and maintenance.

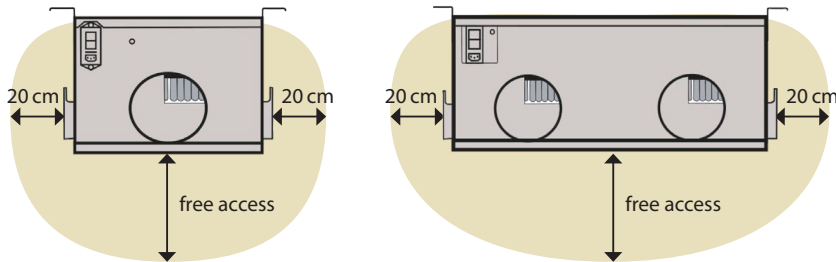

All electronics in the ozone generator can be reached from above the ozone generator and from inside the service hatch, so we recommend additional space around it to facilitate on-site repairs without the need to dismantle the generator first. The ozone generator should be placed in such a way that it can be easily reached using a ladder or servicing platform.

1. Prepare a circular hole in the exhaust duct (6) (7) or in the kitchen hood (8). The diameter of the hole is depended on the tube you select. The diameter must be between  $\varnothing$  80-125 mm. The inlet and outlet pipes on the ozone generator have a diameter of  $\varnothing$ 125mm.
2. Install the ozone generator. (4)

The ozone generator must be installed horizontally with the suspension brackets upward and service hatch downward. Use M8 threaded rods and anchor these with nuts on each side of the respective bracket.

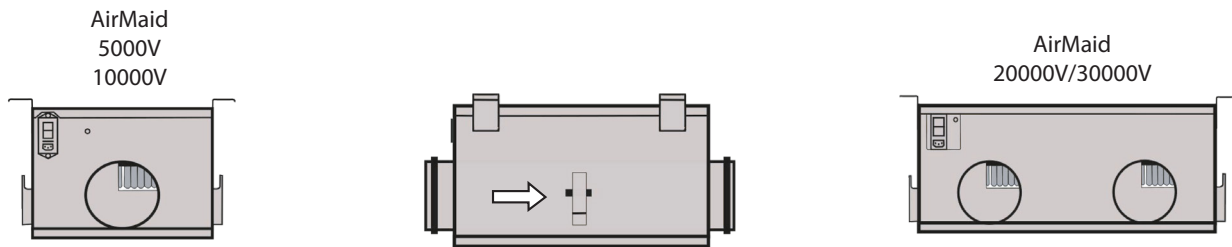

Note that the direction of the airflow  $\Rightarrow$  must correspond to the arrows on the generator and the pictures below.

Make sure that you have selected the correct ozone generator.

AirMaid	Ozone Capacity		Max Treated Exhaust		Airflow through the ozone generator	
	Up to	Use parallel units for higher airflow	Specification	Target		
5000V	5000 mg/h	2500 m <sup>3</sup> /h (700 l/s)	36 - 90 m <sup>3</sup> /h (10-25 l/s)	54 m <sup>3</sup> /h (15 l/s)		
10000V	10000 mg/h	5000 m <sup>3</sup> /h (1400 l/s)	72 - 144 m <sup>3</sup> /h (20-40 l/s)	108 m <sup>3</sup> /h (30 l/s)		
20000V	20000 mg/h	10000 m <sup>3</sup> /h (2800 l/s)	144 - 288 m <sup>3</sup> /h (10-25 l/s)	216 m <sup>3</sup> /h (15 l/s)		
30000V	30000 mg/h	15000 m <sup>3</sup> /h (4200 l/s)	288 - 432 m <sup>3</sup> /h (10-25 l/s)	324 m <sup>3</sup> /h (15 l/s)		

The generator must be easily accessible after installation. Never screw or drill through the generator. Always use the brackets for suspension.

The length of the ozone outlet tube (5) can be maximum 5 m. The minimum dimension of the ozone outlet tube can go down to  $\varnothing$  80 mm. The material of the ozone outlet tube must be stainless steel (AISI 316). Make sure that the tube is not blocking any inspection hatches.

Note that the direction of the airflow must correspond to the arrows on the generator and the picture below.

## FILTER BOX INSTALLATION

Filtered air is required. Remember to add a filter inspection/replacement to the maintenance schedule.

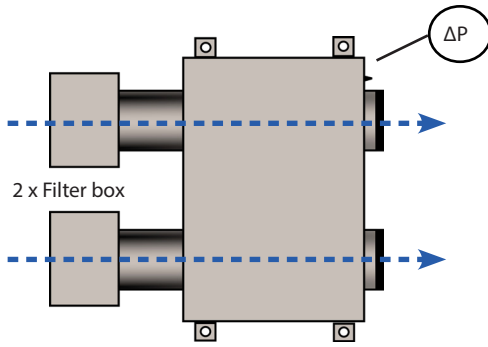

Pressure drop  $\Delta P$  @ Target Airflow rate:  
 20000V: 89 Pa  
 30000V: 110 Pa

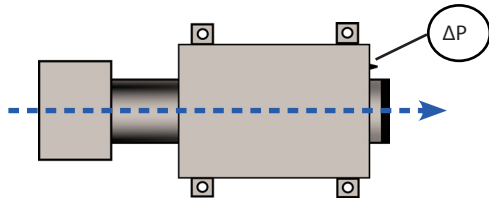

Pressure drop  $\Delta P$  @ Target Airflow rate:  
 5000V: 78 Pa  
 10000V: 130 Pa

## CENTRAL AIR INSTALLATION

With central air installations, dampers are necessary to obtain the target airflow and static pressure.

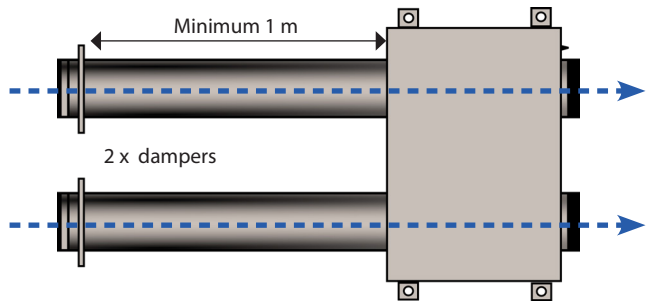

Conditioned air target airflow:  
 20000V: 108 m<sup>3</sup>/h (30 l/s) per pipe  
 30000V: 162 m<sup>3</sup>/h (45 l/s) per pipe

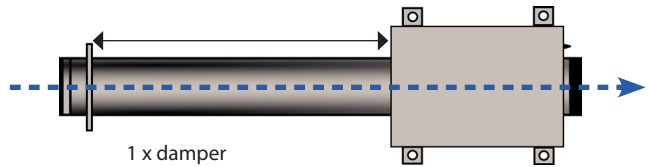

Conditioned air target airflow:  
 5000V: 54 m<sup>3</sup>/h (15 l/s)  
 10000V: 108 m<sup>3</sup>/h (30 l/s)

- Fasten the outlet air tube (5) between the ozone generator and the exhaust duct (6) (7) (or the hood). Make sure that all connections are properly fixed and sealed.

## SPLITTING 20000V/30000V OUTLET PIPES BETWEEN DUCTS (OPTIONAL)

As the AirMaid 20000V generator has two outlet pipes, it is possible to share the generated ozone between two nearby sections of the exhaust duct system. Because each duct section can have a unique pressure, it is the responsibility of the engineer to ensure the proper airflow is delivered into each section of channel.

## MOUNTING THE IRIS DAMPER

The iris damper should be installed at appropriate distance from sources of disturbance, according to the specified assembly specifications for the specific model. This applies to all types of fitting, whether it is a T-pipe, bend or dimensional change.

## 4 ELECTRICAL CONNECTION AND SETTINGS

### ASSEMBLY

Remove the four screws that fasten the AirMaid® alarm panel to its base. Fasten the base to the wall using devices suitable for the wall material. In commercial kitchens place the alarm panel where it will be visible to the staff but not to customers.

**NOTE:** Upon delivery the generator and alarm panel within the shipping carton are calibrated together and have matching serial numbers. Make sure that generators are always connected to their own alarm panel.

### ELECTRICAL INSTALLATION

The installation must be performed by an authorized electrician and follow national standards and regulations. The interlock device displayed on the diagram below is mandatory. A typical example of the interlock would be to shut down the main power to the generator when the exhaust fan is shutting down. Another example would be to remotely shut down the main power to the generator through BACnet. An all-pole safety switch with a break length of at least 3 mm must be installed as well. The electrical requirements for the ozone generator are 230V AC and 50-60 Hz. Each and every generator must be connected to its own slow fuse, 6A for the 5000V/10000V and 10A for the 20000V/30000V.

#### Important!

Under no circumstances may the cable between the alarm panel and generator be used for any external electrical connections or control signaling.

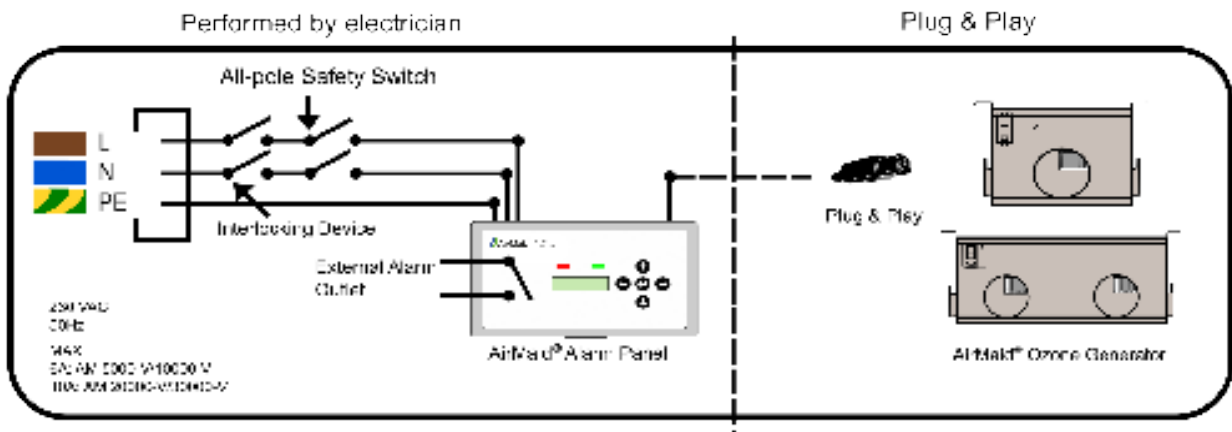

### EXTERNAL ALARM OUTLET

If you desire to connect AirMaid® to an external monitoring or alarm system, you can accomplish this by connecting it to the external alarm terminal block within the AirMaid® alarm panel.

**NOTE:** The maximum load is rated to 250V and 4A.

#### Important!

If the electrical cables are removed during installation, ensure that they are properly reconnected to the "IN" L/N terminals.

Connection to external alarm device. Voltage freerelay output

NO = Normally open  
COM = Common  
NC = Normally closed

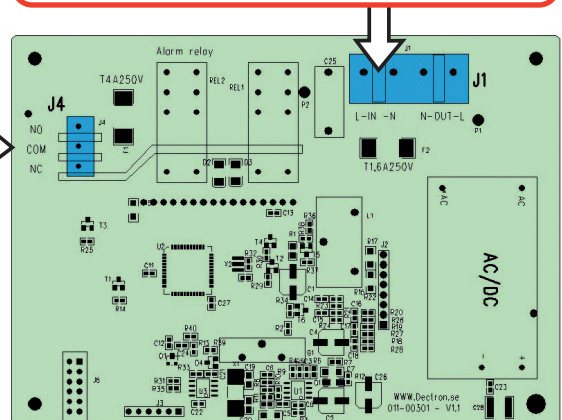



## 5 BACNET CONNECTION AND SETTINGS (OPTIONAL)

### BACnet MS/TP Setup

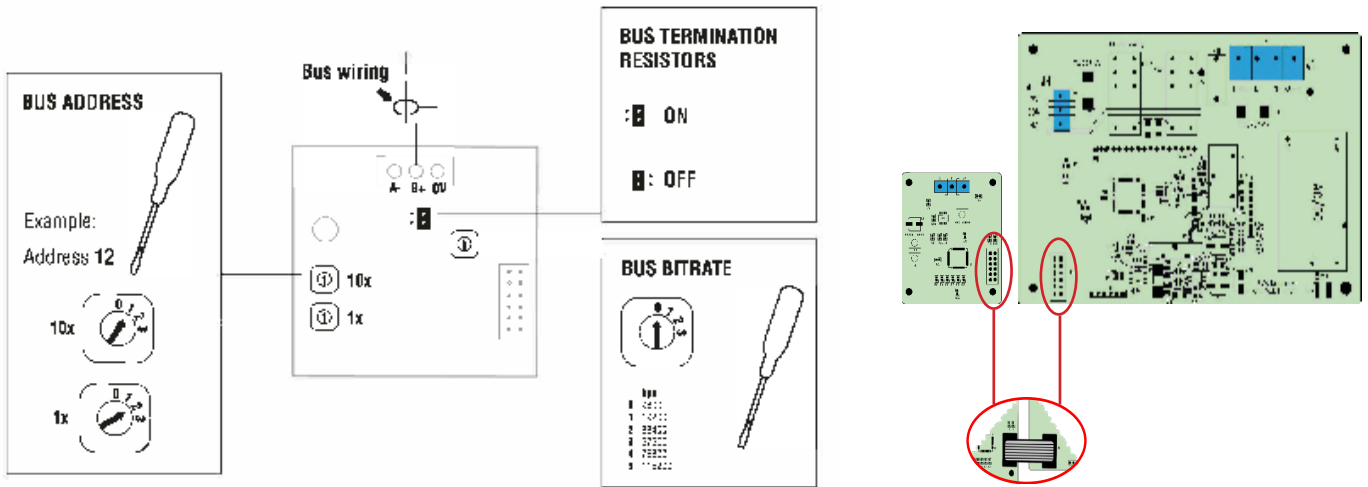

**Vendor Name:** Bithouse Oy

**Product Name:** Absolent CKV AirMaid BACnet MS/TP Addon Card

**Product Description:**

This addon card receives data in JSON –form from the Airmaid panel and makes it visible to other BACnet devices in the same BACnet network.

**BACnet Standardized Device Profile (Annex L):**

BACnet Application Specific Controller (B-ASC).

**List all BACnet Interoperability Building Blocks Supported (Annex K):**

- Data Sharing-ReadProperty-B (DS-RP-B)
- Data Sharing-WriteProperty-B (DS-WP-B)
- Device Management-Dynamic Device Binding-B (DM-DDB-B)
- Device Management-Dynamic Object Binding-B (DM-DOB-B)
- Device Management-DeviceCommunicationControl-B (DM-DCC-B)

**Standard Object Types Supported:**

- Device Object
- Analog Value Object
- Binary Value Object
- Multi-State Value Object

**Data Link Layer Options:**

MS/TP master (Clause 9), baud rate(s): 9600, 19200, 38400, 57600, 76800, 115200.

**Device Address Binding:**

Is static device binding supported?

- No.

**Networking Options:**

Does the BBMD support registrations by Foreign Devices?

- No.

Does the BBMD support network address translation?

- No.

**Network Security Options:**

Non-secure Device - is capable of operating without BACnet Network Security!

**Character Sets Supported:**

ISO 10646 (UTF-8).

## SYSTEM STATUS

[1]	Unknown
[2]	Running
[3]	Please Call Service
[4]	Inspect / Clean
[5]	Offline: Not Connected
[6]	Offline: Pressure
[7]	Calibration Fail: Pressure
[8]	Remotely Disabled

## OPTIONS

<b>INSPECTION INTERVAL</b>	Service and maintenance interval in months.
<b>SET INSPECTION INTERVAL</b>	Change Present Value between 1-12. Default 12 months.
<b>TIME LEFT TO INSPECTION</b>	Default 360 days.
<b>ALARM DELAY</b>	The delay time before we receive an alarm if a component failure occurs.
<b>SET ALARM DELAY</b>	Change Present Value between 2s-24h. Default 2s.
<b>PFNC</b>	The delay time before we receive an alarm about a pressure issue or that the unit is switched off.
<b>SET PFNC</b>	Change Present Value between 2s-24h. Default 5min.
<b>EVENT LOG POSITION</b>	The amount of events that have been logged.
<b>POWER, CALIBRATED</b>	The current value that the alarm panel is calibrated to.
<b>POWER, ACTIVE</b>	The actual value that the alarm panel has detected.

## 6 AIRMAID STARTUP

Once you have adjusted and configured the required airflow and under-pressure, you can then apply power to the generator. The first time the alarm panel is started the time and date must be configured.

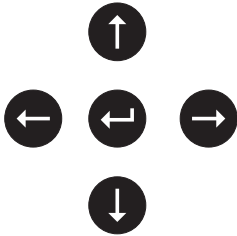

Press ← or → to step through menu options or reposition the cursor.

Press ↑ or ↓ to change the value.

Press ↵ to select the current option.

Press ↵ for 5 seconds to save the displayed value.

### STATUS OF OPERATION

#### RUNNING:

Green lamp is on solid. Normal operation.

#### INSPECT/CLEAN:

Green lamp is blinking. Contact your service company for a routine inspection and cleaning of the generator as described in this guide.

#### PLEASE CALL FOR SERVICE

The generator is operating, however it is not running at full for service capacity. Partial failure: Red lamp is blinking, green is on solid. Severe failure: Only the red lamp is blinking (from version 3.01).

#### AIRMAID OFFLINE SYSTEM PRESSURE

Red lamp is blinking. The system has detected a problem with the static pressure. The grease filters in the kitchen hood may not be installed correctly, or the extract air fan is switched off or the inspection hatches are open (from version 3.01).

#### AIRMAID OFFLINE NOT CONNECTED

Red lamp is blinking. The generator is not switched on. The main switch on the generator may be turned off, or perhaps the power supply cable from the Alarm Panel is not connected to the generator (from version 3.01).

#### CALIBRATION FAIL NOT CONNECTED

Red lamp is blinking. A calibration was performed while the generator was not running. The main switch on the generator may be turned off, or perhaps the power supply cable from the Alarm Panel is not connected to the generator (from version 3.01).

#### CALIBRATION FAIL AIRMAID PRESSURE

Red lamp is blinking. A calibration was attempted while the system detected a problem with the static pressure. The grease filters in the kitchen hood may not be installed correctly, or the extract air fan is switched off or the inspection hatches are open (from version 3.01).

### ENTERING/EXITING THE SETTINGS MENU

#### To ENTER the settings menu:

Press ↵ once. "SETUP CODE" will be displayed. Enter 401 on the keyboard.

Press and hold ↵ for 5 seconds. At this time "SET TIME" will appear and you may use the ← and → keys to traverse within the settings menu to perform the necessary tasks.

#### To EXIT the settings menu:

Press ← or → to go to "EXIT MENU", then press ↵ or wait 60 seconds and the menu will be closed automatically.

### 3-YEAR PRODUCT WARRANTY

REMEMBER to submit the product registration form to Absolent CKV within ten (10) days after the completion of the installation in order to receive a **3-year warranty**. The warranty will then be valid from the installation date. The easiest way to do so is by scanning the QR-code the right and submitting the form. The whole process will only take a couple of minutes.

AirMaid® product registration



## SETTINGS OPTIONS (\*values that should be set at time of installation)

Text displayed	Description of the menu option
* SET TIME:	Set the time.
* SET DATE:	Set the date.
VIEW EVENT LOG:	View a list of historic events, including alarms and recalibration. The 100 most recent events will be displayed
SET ALARM DELAY:	The delay time before we receive an alarm if a component failure occurs. By default, this delay is set to 2 seconds (from version 3.01).
SET PF-NC DELAY:	The delay time before we receive an alarm about a pressure issue or that the unit is switched off. By default, this delay is set to 5 minutes (from version 3.01).
SET INSP/CLEAN:	Service and maintenance interval in months.
PERFORM RECALIBRATION:	This menu selection may <b>only</b> be performed after a repair.
PERFORM HARD RESET:	Performs a hard reset of the alarm panel that temporarily shuts down the unit for 5 seconds (from version 3.01).
EXIT MENU:	Exit the settings menu.

## SETTINGS MENU FLOW DIAGRAM

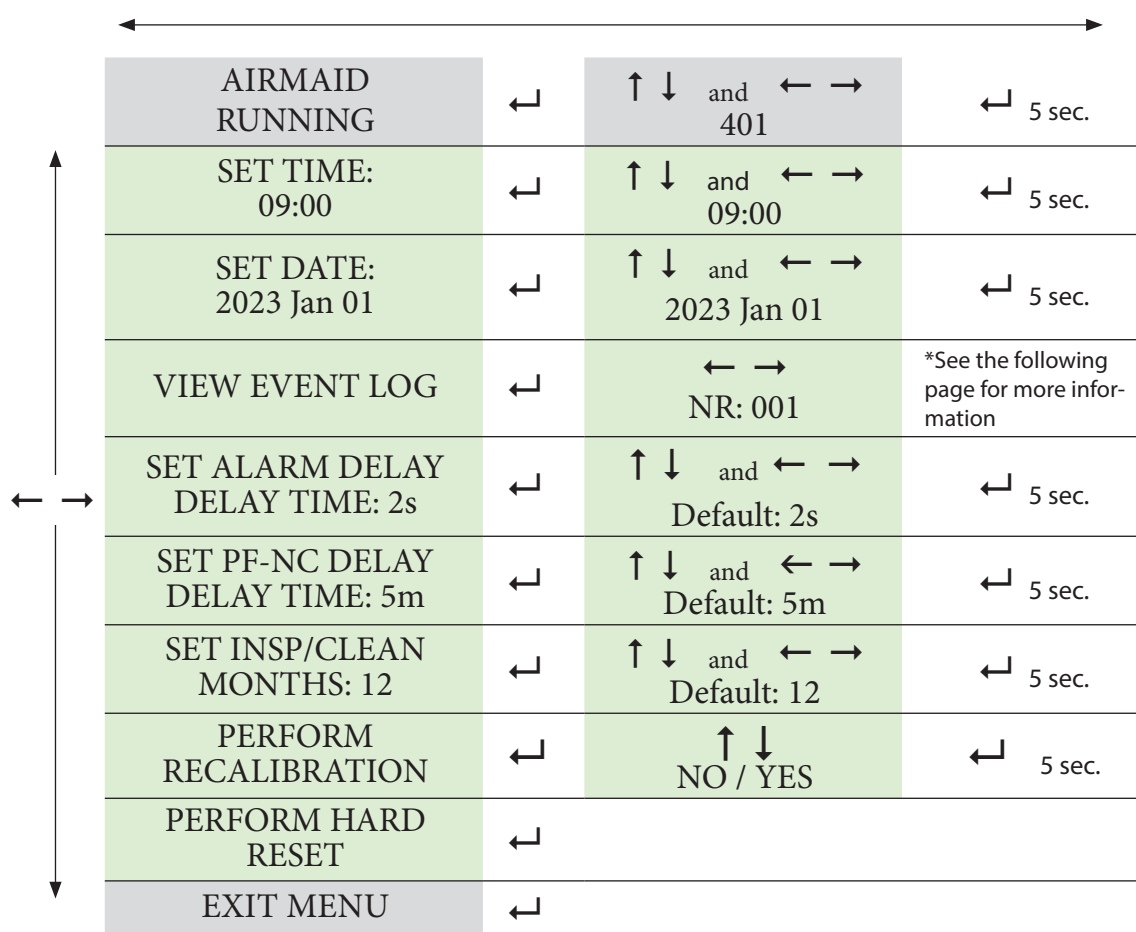

## EVENT LOG

1.2. 3.  
NR: 005P 00000h  
2018AUG04 10:00  
4. 5.

### CAUSE

A = Alarm

C = Calibration

P = Pressure Fault

N = Not Connected (ozone generator not detected)

D = System Remotely Disabled (Interlock by BACnet)

1: Number of registered events 2: Cause 3: Event Duration 4: When (Year/month/day) 5: When (Time)

---

## KEYPAD FUNCTIONS

### INSPECT/CLEAN

AIRMAID  
INPECT/CLN 360d

Press ↑ to display days how many days remain until the next inspecton.

**DISMISS REMINDER:** Press and hold ← for 5 seconds to dismiss the reminder message on the display.

**RESET REMINDER:** Enter 222, then press and hold ← for 5 seconds to reset the the reminder timer (perform this if cleaning is performed before the timed reminder is displayed)

### RUN/ALARM TIME FUNCTIONS

RUN TIME 667h  
ALARM TIME 12m

Press ↓ to display Run time and alarm time since initial installation.

### INFORMATION ABOUT THE ALARM PANEL

HARDWARE 2  
FIRMWARE 3.01

Press ← to display Alarm Panel **Hardware** and **Firmware** versions.

### SYSTEM LOAD INFORMATION

pCalib: 396  
pActive: 394

Press → to display system load values **pCalib** and **pActive**. These are diagnostic values that can assist your AirMaid authorized service company to troubleshoot system errors (from version 3.01).

## 7 SYSTEM TEST

### AIR FLOW AND PRESSURE

Measure the airflow through the ozone generator and note the value here \_\_\_\_\_

Measure the pressure inside the ozone generator and note the value here \_\_\_\_\_

**The values must be transferred to the attached product registration.**

The specified airflow must be 10–25 l/s for the 5000V, 20–40 l/s for the 10000V, 40–80 l/s for the 20000V and 60–120 l/s for the 30000V. The specified pressure must be less than -25 Pa (max -500 Pa). Usually the airflow is measured over the damper while the pressure can be measured from the pressure checkpoint on the short side of the ozone generator.

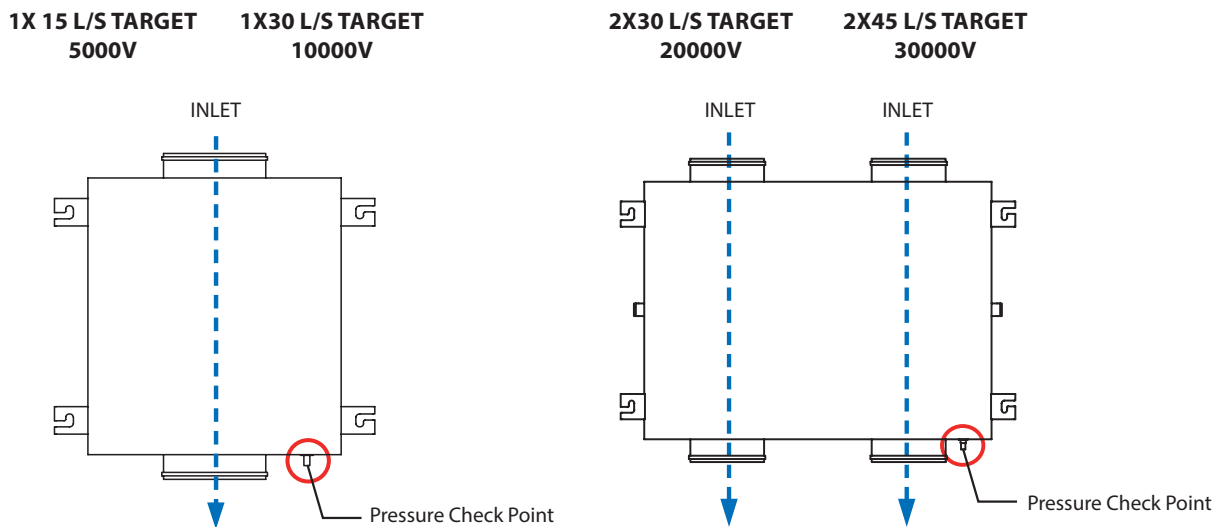

### TROUBLESHOOTING

1. Ensure that the correct airflow and pressure is maintained according to the specification.
2. Ensure that the electrical wiring is correctly installed.
3. Ensure that the exhaust fan is running.
4. Ensure that the grease filters are properly installed in the hoods in the kitchen.
5. Ensure that the main power switches are ON (orange light must glow) at the ozone generators.
6. Ensure that the interlock is working properly.
7. Ensure that there is no leak in the tubing after the ozone generator.
8. If the ozone generator is installed with a filter box, make sure that the filter is clean.
9. Reset the active alarm, see section "6 AIRMAID STARTUP".
10. If the system still does not start call the distributor or the manufacturer.

## 8 SERVICE AND MAINTENANCE

The ozone cells inside the ozone generator must be checked and if necessary cleaned at least once per year according to the instructions below. If a separate air filter is used for the inlet air, make sure that this filter is changed at least one time per year. With a new installation it is recommended to perform a first inspection after three months.



If any work needs to be performed in the kitchen extraction ducts, the power to the ozone generator must be disconnected.

Switch **OFF** the main power to the ozone generator and then remove the service hatch from the bottom of the ozone generator.

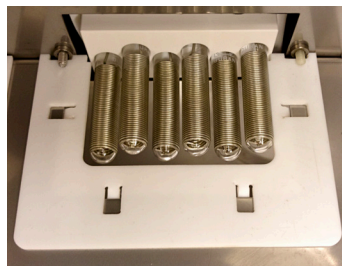

**Note:** AirMaid® 5000V has one set of ozone cells; 10000V has two sets; and 20000V has four sets and 30000V has six sets.

Make sure that the glass electrodes of the ozone cells are not damaged or cracked. A proper ozone cell should be clean and free from any mechanical damage according to the picture to the right above.



Wet a soft, durable cleaning cloth with your alcohol-based cleaning spirit. **Never spray directly onto the ozone cell!**

**Caution! the glass tubes are fragile!**  
Use only your hands and never any sort of tool to scrape or clean the ozone cell.



First clean the surfaces of the glass electrodes and then around the base of the cell. Using your fabric like dental floss, gently clean between the electrodes with a gentle sliding movement.



Finally, wipe clean the inside of the chassis.

**Note:** Remember to check the mesh filter(s) and wash them if necessary.

(Spare filter(s) can be ordered from Absolent CKV).

Put the service hatch back on and turn **ON** the main switch on the generator. Within a few minutes the green light on the alarm panel should light up, this indicates that the generator is back on.

## 9 TECHNICAL SPECIFICATIONS

AirMaid	Ozone Capacity Up to	Power	Voltage	Main Breaker	Dimensions	Weight
5000V	5000 mg/h	100 W	230V/50-60 Hz	6A Slow	300 x 402 x 252 mm	10 kg
10000V	10000 mg/h	200 W	230V/50-60 Hz	6A Slow	300 x 402 x 252 mm	12 kg
20000V	20000 mg/h	400 W	230V/50-60 Hz	10A Slow	572 x 402 x 252 mm	24 kg
30000V	30000 mg/h	500 W	230V/50-60 Hz	10A Slow	838 x 402 x 252 mm	25 kg
Material: AISI 304 stainless steel					Operating temp: -25° to +40°C	

For air flow and pressure specifications, see section 3, "INSTALLATION GUIDELINES".

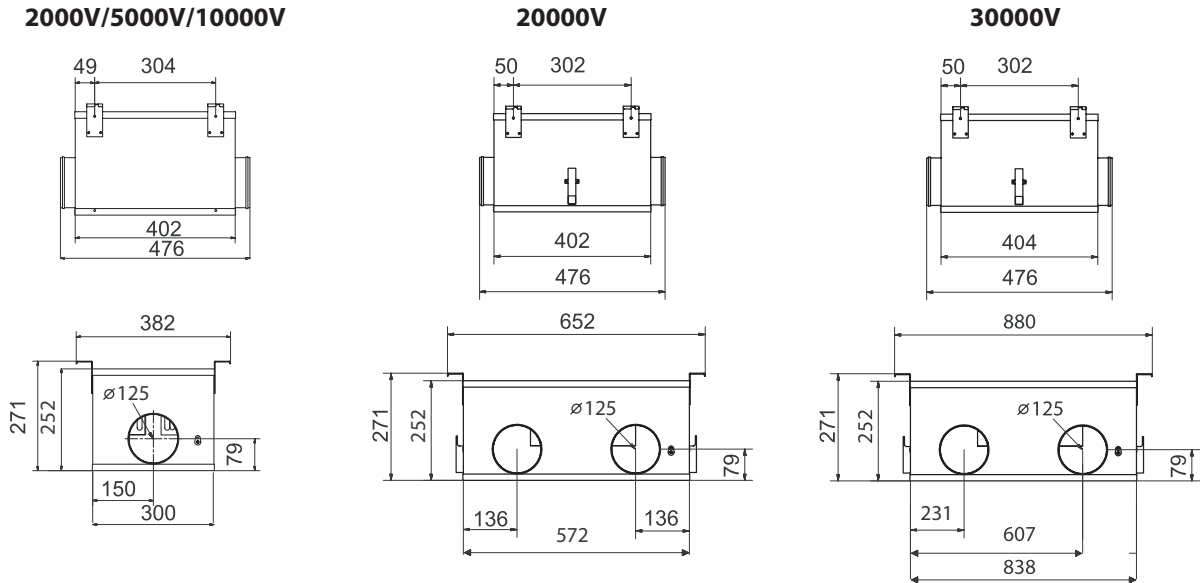

The ozone generator is supplied with a pressure and thermal switch. The pressure switch ensures that the ozone generator only starts when the required negative pressure is established. The thermal switch prevents the ozone generator from overheating. The main switch for the 5000V/10000V is supplied with a thermal overload protection of 2A and the main switch for the 20000V/30000V is supplied with a thermal overload protection of 4A.

### EC DECLARATION OF CONFORMITY



This product has been designed, constructed and distributed in compliance with the safety requirements of EC Directives:

- EMC directive 2014/30/EU
- Low voltage directive 2014/35/EU



This symbol indicates that when the end-user wishes to discard this product, it must be sent to separate collection facilities for recycling.

### Facts about Ozone

Ozone is a colorless gas with a pungent smell that can often be detected by any person at a concentration of 0,02ppm (0,4mg/m<sup>3</sup>). The smell of ozone is similar to chlorine like in a swimming pool.

Local protection legislations must be followed when using ozone. In Sweden, for example, the Swedish Work Environment Authority issues the following hygienic limits for ozone:

- 0,1ppm (during a working day, 8 hours)
- 0,3ppm (during 15 minutes)

At acute exposure ozone can cause following injuries:

- On skin: Irritation and burning feeling
- In eyes: Hard irritation, burn injuries and reduced vision
- In lungs: Irritated effect on respiratory organs and breathing problems

Always take corrective action and safety precautions if ozone is detected in an indoor environment.

### The AirMaid V ozone generators comply with EN 16282-8:2017 »Equipment in commercial kitchens – elements for ventilation (Part 8)

The European Standard EN16282 for the ventilation of commercial kitchens sets requirements for air-fed ozone generators in order to limit the production of nitrogen oxides and nitric acid. The standard stipulates that oxygen-fed systems are used with a total extraction volume of more than 2500 m<sup>3</sup>/h. The air-fed AirMaid V generators meet this requirement. Each CGC ozone cell installed in the generators, which is surrounded by a volume flow of up to 54 m<sup>3</sup>/h, can only clean up to 2500 m<sup>3</sup>/h total extraction volume. Even with larger total extraction volumes, the AirMaid V generators can therefore be used safely, even if they are not oxygen-fed.



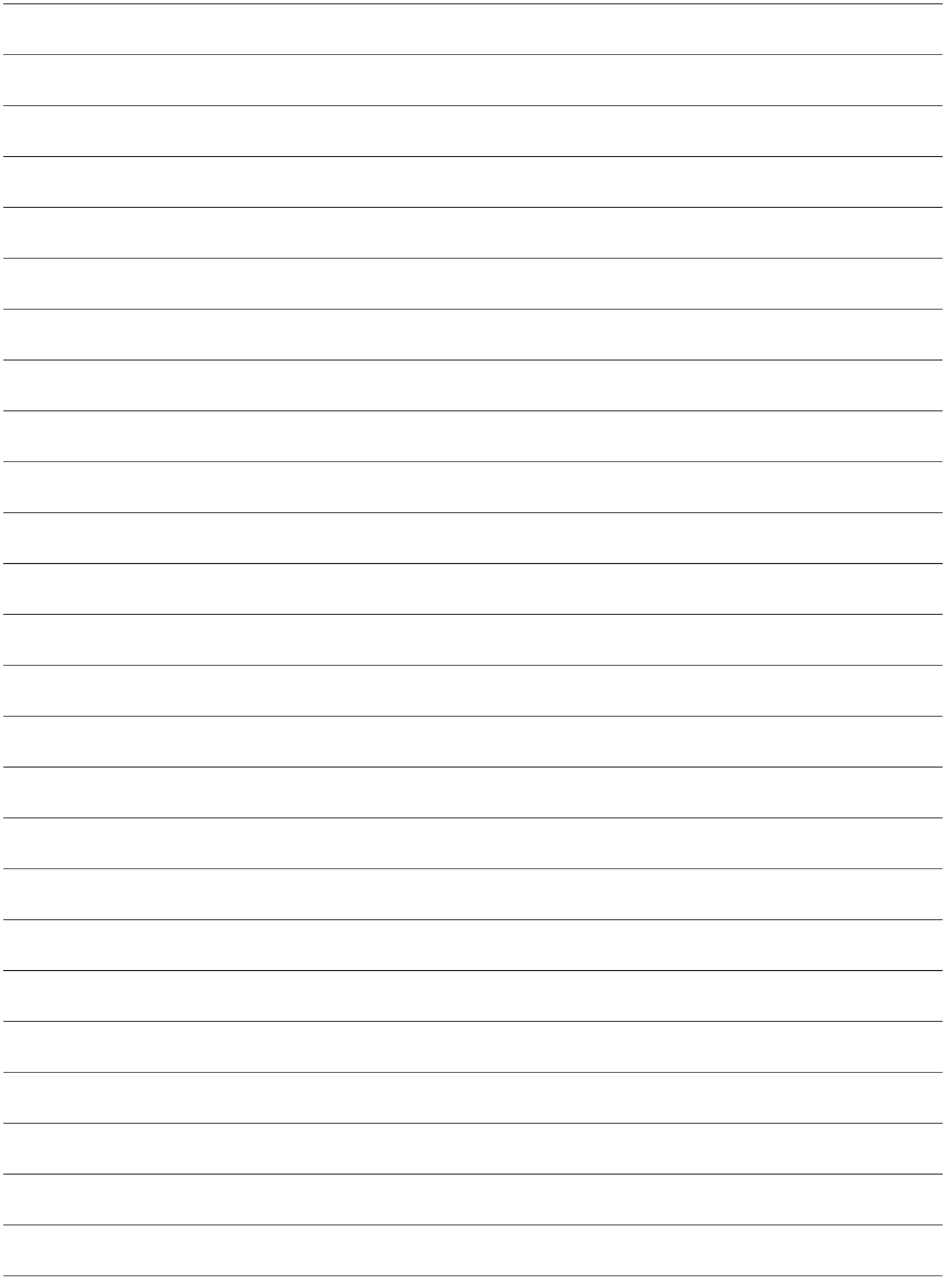

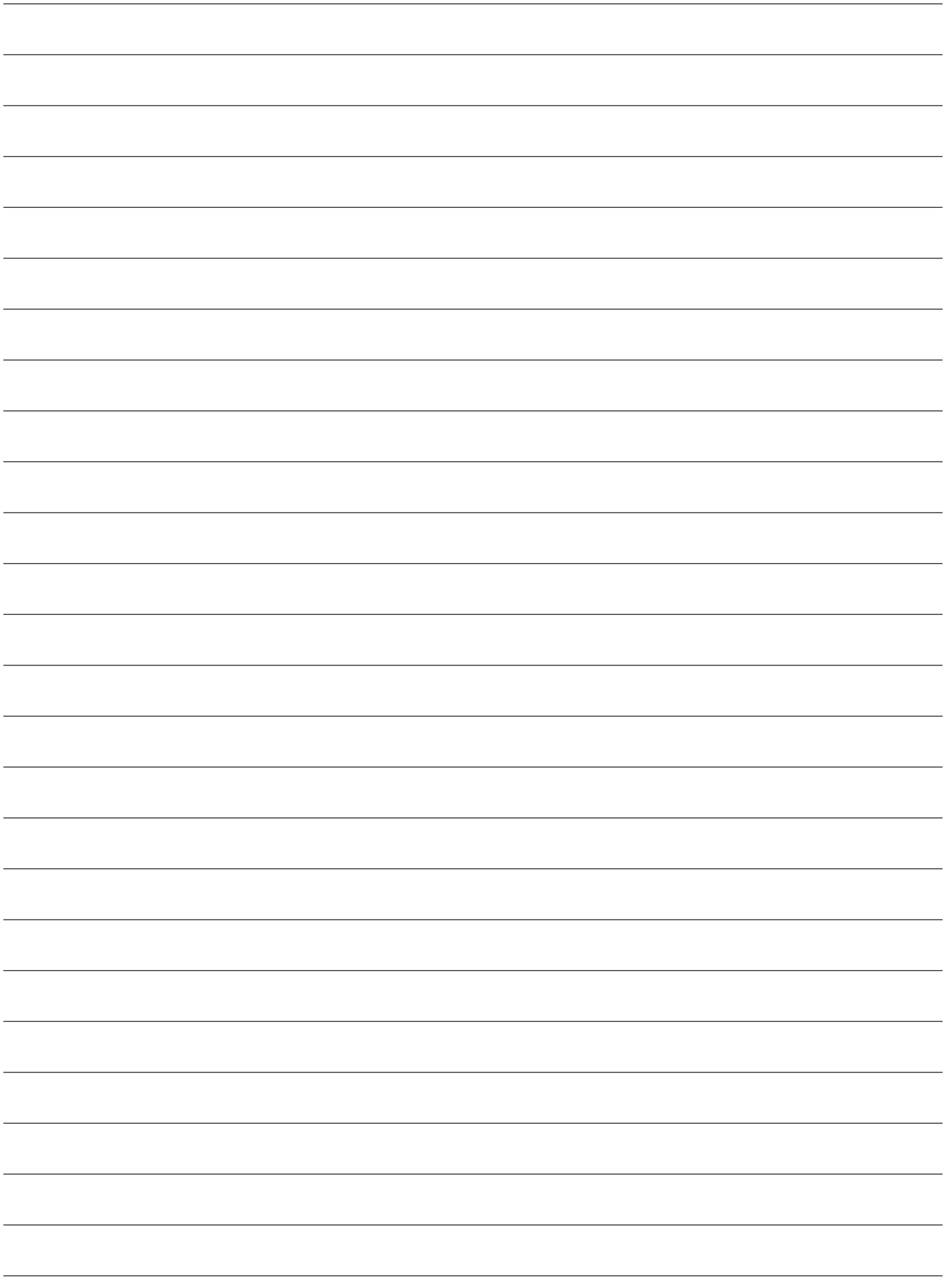



Reproduction, modification or translation without a prior written consent is forbidden with the exception of what is permitted by the Act on Copyright.

Original Instructions

Copyright Information

© 2024 Copyright Absolent CKV AB

Edition 11 07/24

Distributor:



Part of Absolent  
Air Care Group

Manufacturer:

Absolent CKV AB  
Reprovägen 12, 2tr  
SE-183 77 Täby, Stockholm  
Sweden

Email: [info@absolentckv.com](mailto:info@absolentckv.com)  
Internet: [www.airmaid.com](http://www.airmaid.com)